

**BOXER 30**

**VACUUM PACKAGING MACHINE**



**FEATURES**

- Standard with 1 seal bar (front): 350 mm
- Standard double seal (two wires). Optional without extra costs: Cut-off/Wide seal
- Seal bar easily removable for cleaning and maintenance purposes
- Pump capacity: 8 m<sup>3</sup>/h Busch vacuum pump
- Pump maintenance and cleaning program
- Machine cycle: 25-45 sec
- Standard Digital control with Time control and a 10 program memory
- Standard Soft Air to protect the product and vacuum bag
- Deep drawn stainless steel vacuum chamber
- Stainless steel exterior and transparent lid
- Comes with insert plate for a faster cycle and product adjustment

**OPTIONS**

- 1-2 Cut-off seal
- Sensor control/Advanced Control System
- Liquid control
- Gas flush

**ACCESSORIES**



- Zebra ZD410 thermal label printer (only in combination with Advanced Control System)
- Inclined insert plate (for packing liquids)
- Food container adaptor
- Service kit for standard maintenance
- Trolley with shelve

**DESCRIPTION**

The robust, stainless steel Boxer 30 vacuum packaging machine is standard equipped with a Busch vacuum pump and Digital control with a 10 program memory. This table-top model complies with CE standards.

**SEAL BAR CONFIGURATION**

Standard

Henkelman offers standard 3 year warranty

# VACUUM PACAGKING MACHINE BOXER 30- SPECS

VACUUM PACKAGING MACHINE BOXER 30 - SPEC SHEET

## DIMENSIONS

In mm

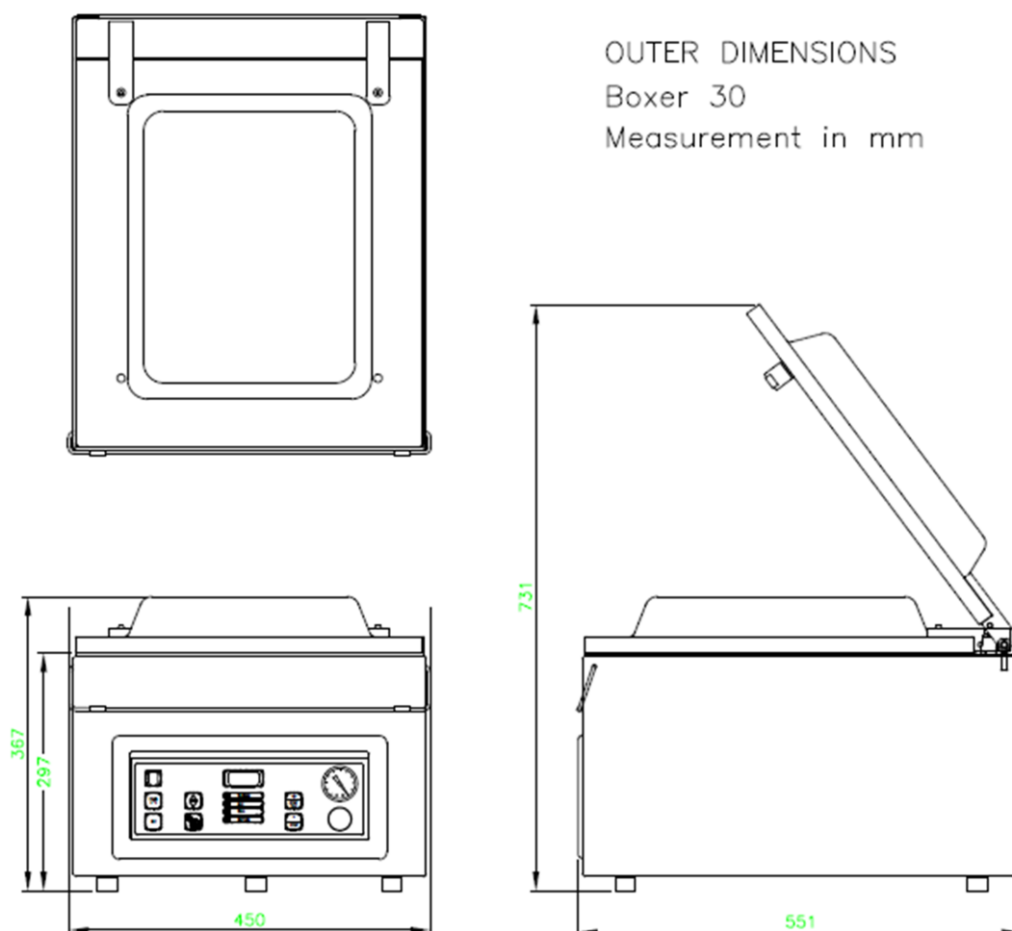

Model	Dimensions (mm)		Voltage* (Hz)	Pump capacity (m <sup>3</sup> /h)	Power (kW)	Weight (kg)
	Chamber (usable space) L x W x H	Machine L x W x H				
Boxer 30	370 x 350 x 150	551 x 450 x 367	230V-1-50	8	0,4	46
* Other voltages available						



HENKELMAN BV  
Titaniumlaan 10  
5221 CK 's-Hertogenbosch  
The Netherlands

**Sales support**  
P +31 73 621 36 71  
E [info@henkelman.com](mailto:info@henkelman.com)  
**Service/technical support**  
P +31 73 621 36 71  
E [service@henkelman.com](mailto:service@henkelman.com)